

TRIMBLE EARTHWORKS GO! 2.0

2D GRADE CONTROL SYSTEM FOR COMPACT GRADING ATTACHMENTS

Trimble Earthworks GO! 2.0 is the next generation of compact machine control, designed to enable system expandability and upgrades so your investment remains valuable and updated over time. Trimble Earthworks GO! 2.0 provides high-accuracy grading capability while reducing capital expense. This user installable, low-cost solution is the ideal first step into machine control for small contractors and owner operators. Compact, easy to use and highly portable, the system can quickly be moved from attachment-to-attachment for increased utilization and fast return on investment.

SYSTEM FEATURES

- iOS and Android™ compatibility allows operators to use their smart device as the primary machine interface
- Trimble technology enables full sensing technology with no mounting hardware required
- Simple harnessing provides a low-profile, easy to maintain solution
- 2D automatic grade control
- Integrated installation and calibration tutorials that make setup easy
- Proven laser-guided technology enables high precision grading in less time
- Slope control with no laser to easily grade without any setup required
- Save machine profiles to enable one-time setup

UNPARALLELED PORTABILITY

Trimble Earthworks GO! proprietary Trimble GO! 2.0 Box technology lets contractors quickly swap the system between machines to take care of the job at hand. Save machine profiles to the GO! 2.0 Box to ensure you only have to set up your machines once, so you can get back to work.

Ultra-portable and intuitive, Trimble Earthworks GO! provides high accuracy performance in all common grading applications such as pads, parking lots, sports fields, landscaping and more. It also works across the entire fleet of attachments for compact track and skid steer loaders.



EASY-TO-USE, PORTABLE PLATFORM



Smart Device User Interface

- Designed for visibility in bright daylight
- Intuitive software design for unmatched ease of use
- Integrated setup tutorials to get up and running faster than ever



Trimble LR410 Laser Receivers

- 9 in (23 cm) detection window for maximum working range
- Can work with OEM masts or Trimble manual masts
- Perfect for high precision grading needs

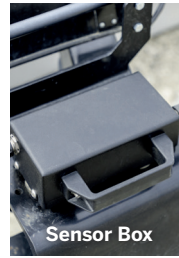

Sensor Box

Trimble GO! 2.0 Boxes

- Fully portable with magnetic mounts
- Ruggedized for construction environments and exposure to the elements
- Trimble Comms Box contains a Bluetooth® communications device
- Trimble Sensor Box contains the system IMU



Comms Box

DUAL LASER SYSTEM

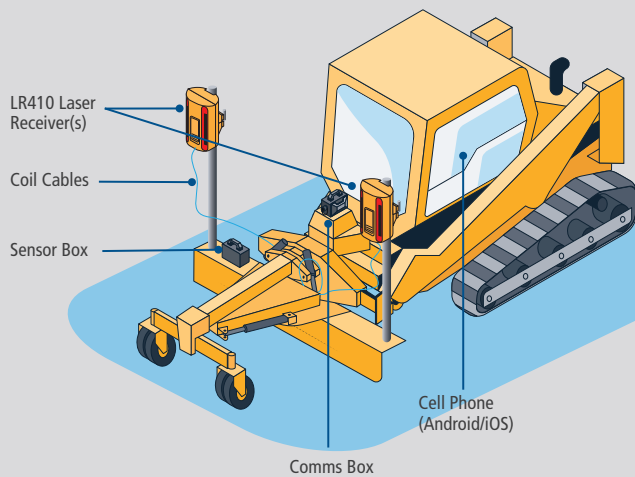

SINGLE LASER SYSTEM

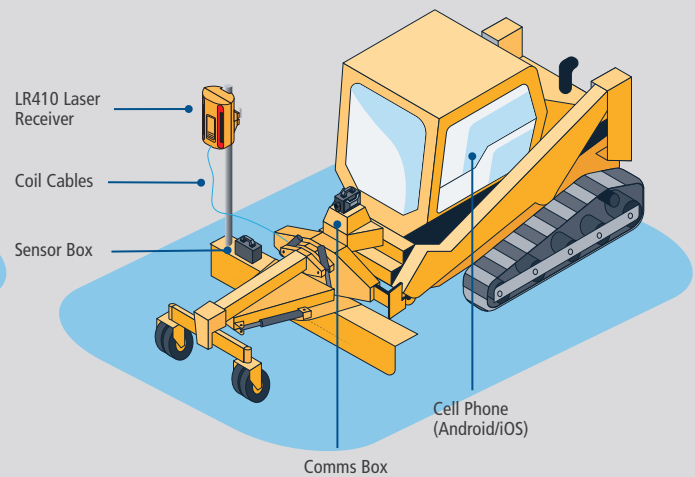

CROSS SLOPE ONLY

